

Student ID:

Name:

Exam IST 441 Spring 2009

- Last name: _____ First name: _____
- Student ID: _____
- I acknowledge and accept the University Policies and the Course Policies on Academic Integrity

This 100 point exam determines 30% of your grade.

There are 10 extra credit questions which graduate students have to answer but are optional for undergrads.

If you use the back of any paper, please note on the front.

Student ID:

Name:

Information Retrieval (15 pts)

- You are asked to design and implement an information retrieval / search engine system for enterprise search.
 - (5pts) Explain to your clients what a search engine is by describing its basic components and what each does.

Student ID:

Name:

Document Analysis (35 pts)

- (5 pts) What is the document vector model, why is it important and how is it used by information retrieval and modern search engines? Describe what tokens are and how they are represented.

- Consider the following documents D and queries Q for the following:
 - D1: you say goodbye
 - D2: hello goodbye hello goodbye hello
 - D3: I say hello
 - Q1: I hello
 - Q2: hello goodbye

- (5 pts) Define for the above documents and queries the token vocabulary.

Student ID:

Name:

Document Vectors

- (5 pts) Using the 3 documents and 2 queries, construct the document vector for each document and query with term or token frequency weights.

Student ID:

Name:

Inverted index

- (5 pts) Construct the dictionary file and posting file for the 3 documents

Student ID:

Name:

Document Similarity and Ranking

- (5 pts) Define the inner product similarity metric between a document and a query.
- (5 pts) Construct the inner product for the term frequency document vectors for all documents with all queries. Make sure you show all the computation.
- (5 pts) Rank the documents for each query.

Student ID:

Name:

Document Similarity and Ranking

- (5 pts - extra credit) Define the cosine similarity metric between documents and queries.

Student ID:

Name:

Precision-Recall (20 pts)

- (5 pts) Define relevance; contrast it with importance.
- (5 pts) Define recall and precision in terms of relevant and irrelevant documents. Use set drawings to explain both.
- (3 pts) Which is more important for a search engine, recall or precision? Why?

Student ID:

Name:

Precision-Recall Calculation

- (7 pts) Consider the following universe of documents:
 - D1, D2, D3, D4, D5, D6, D7
 - For a particular query, documents D1, D2, D4 are relevant. However our information retrieval system returns D1, D2, D3, D5, D7.
 - Calculate the Recall and Precision for this query. Be sure you show what documents belong in the ratio values for complete credit. Do not just put in a number.

Student ID:

Name:

Pagerank Calculation (10 pts)

- (10 pts) From from ranked pages, calculate pagerank for the unranked pages, A, B, & C giving values for the links used. Also calculate the values on the outgoing links from pages A, B, & C.

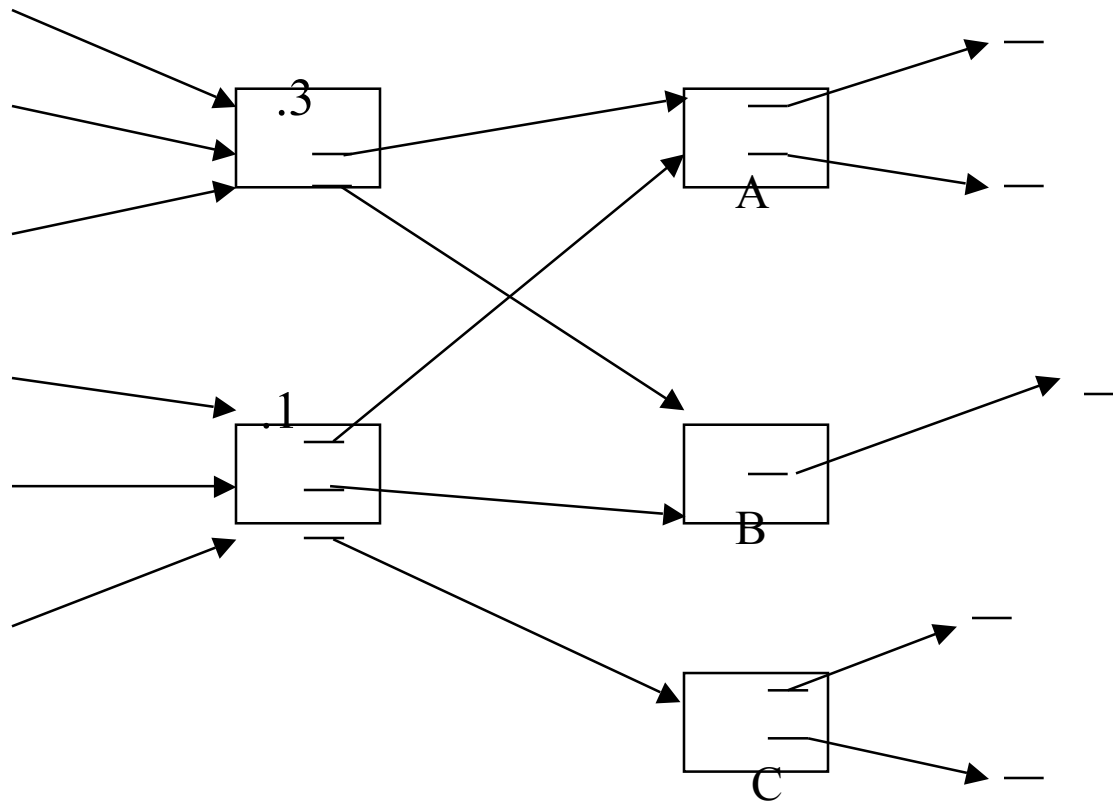

Student ID:

Name:

Social network analysis (10 pts)

- Consider the following actors (nodes) and relations (edges)

Nodes:

P1: Puck, P2: Jean, P3: Nat, P4: Yang, P5: Kate, P6: Jay, P7: Nan, P8: Elf

Edges:

P1 <-> P2, P1 <-> P5, P2 <-> P3

P2 <-> P4, P3 <-> P6, P4 <-> P5

P4 <-> P6, P6 <-> P7, P6 <-> P8

- (6pts) Consider all edges as undirected. Construct the social network matrix and the graph.

- (2pts) Find the shortest path(s) from P2 to P8. Label the path(s).

- (2pts) Which node(s) has the largest degree?

Student ID:

Name:

Extra credit - size of things (5 pts)

- (5 pts) What is the size of Google?